

Field Manual
Case Deflector (Accessory)
Installation Procedures, Maintenance, and
Spare Parts



To contact Intelligrated:
For service: Customer Service and Support (CSS)
Hotline 1-877-315-3400
On the World Wide Web: www.intelligrated.com

By mail:

Intelligrated
7901 Innovation Way
Mason, OH 45040

(513) 701-7300

Read these documents thoroughly before attempting to perform maintenance or repairs to the applicable Intelligrated conveyor system components or devices. Exercise extreme caution when working around moving and rotating conveyor equipment. Wear the proper clothing and safety equipment. DO NOT attempt to perform any maintenance until the equipment is de-energized, locked out and tagged out in accordance with established company procedures.

The information presented in these documents are correct at the time of publication. Intelligrated has made every effort to ensure that the information presented is correct and free from error. However, some errors or misprints may occur. Please contact Intelligrated with any corrections.

This document is copyrighted © 2010 by Intelligrated, all rights reserved. No Part of this manual may be reproduced and/or distributed to parties other than the customer and the customer's employees for whom it was originally produced.

The following terms are trademarks™ of Intelligrated; Accuglide™, BOSS™ UniSort™, EZ-set™. The following terms are registered trademarks® of Intelligrated; Accuzone®, UniSort®, E-Z Set®. Intelligrated® is a registered trademark.

Direct questions and comments concerning the information contained in this manual to:

Documentation Department
Intelligrated
7901 Innovation Way
Mason, OH 45040

Ph (513) 701-7300
Fax (513)701-7349

customerservice@intelligrated.com

Section G Installation Procedures 1

Introduction ----- G-1

 Accepting Shipment ----- G-1

 Shortages or Errors ----- G-1

 Lost or Damaged Shipment ----- G-1

 Claims and Returns ----- G-1

 Codes and Standards ----- G-1

 Warning Signs ----- G-2

 Safety Features ----- G-2

 Parts Replacement ----- G-2

 Factory Assistance ----- G-2

Installing the Case Deflector ----- G-3

 Preparation ----- G-3

 Determine the Installation Location ----- G-5

 Install the Support Assembly ----- G-7

 Install the Deflector Arm ----- G-8

 Check Proximity Switches (Optional) ----- G-11

 Pressure Adjustment & Final Check ----- G-12

Section H Maintenance

Initial Start-Up & Run-In Period ----- H-1

Scheduled Maintenance ----- H-2

 Daily Maintenance ----- H-3

 Every 8 hours of operation ----- H-3

 Weekly Maintenance ----- H-3

 Every 40 hours of operation ----- H-3

 Monthly Maintenance ----- H-3

 Every 160 hours of operation ----- H-3

 Quarterly Maintenance ----- H-4

 Every 520 hours of operation ----- H-4

Troubleshooting ----- H-5

Section I Spare Parts

Parts Replacement ----- I-1

SECTION G:INSTALLATION PROCEDURES

Introduction

Accepting Shipment

Immediately upon delivery, check that all equipment received agrees with the bill of lading or carrier's freight bill. Any shipping discrepancy or equipment damage should be clearly noted on the freight bill before signing.

Shortages or Errors

Report any shortages or errors to the Customer Service in writing within ten (10) days after receipt of shipment.

Note: It is very important that you compare the Order Acknowledgment against the actual material received when you receive the shipment so you have enough lead time to order any missing parts. If you find that a part is missing during assembly, you may have to discontinue assembly while you wait for the part to arrive.

Lost or Damaged Shipment

Report lost shipments to our Shipping Department.

If shipping damage is evident upon receipt of the conveyor, note the extent of the damage on the freight bill and immediately contact the transportation carrier to request an inspection. Do not destroy the equipment crating and packing materials until the carrier's agent has examined them. Unless otherwise agreed by the seller, the Purchaser (user) shall be responsible for filing claims with the transportation carrier. A copy of the inspection report along with a copy of the freight bill should be sent to our Traffic Department.

Claims and Returns

All equipment furnished in accordance with the Manufacturer's Agreement is not returnable for any reason except when authorized in writing by the Seller. Notification of return must be made to the Customer Service Department, and if approved, a "Return Authorization Tag" will be sent to the Purchaser (user). The return tag, sealed in the "Return Authorization Envelope" should be securely affixed to the exterior surface on any side of the shipping carton (not Top or Bottom), or affixed to any smooth flat surface on the equipment, if not boxed.

Send authorized return shipment(s) transportation charges prepaid to the address indicated on the Return Authorization Tag. If initial shipment is refused, the Purchaser (User) shall be liable for all freight charges, extra cost of handling, and other incidental expenses.

Codes and Standards

The conveyor equipment is designed and manufactured to comply with the American National Standard Institute's "SAFETY STANDARDS FOR CONVEYORS AND RELATED EQUIPMENT" (ANSI/ASME B20.1) and with the National Electrical Code (ANSI/ NFPA70).

The Purchaser/User shall be familiar with, and responsible for, compliance with all codes and regulations having jurisdiction regarding the installation, use, and maintenance of this equipment.

Warning Signs

Warning signs and labels posted on or near the conveyor equipment shall not be removed, painted over, or altered at any time. All safety devices, warning lights, and alarms associated with the conveyor system should be regularly tested for proper operation and serviced as needed. If the original safety item(s) become defective or damaged, refer to the conveyor parts list or bills-of-materials for replacement part numbers.

Safety Features

- Do turn off conveyor power source(s) and affix appropriate lockout/tagout device(s) to operating controls before servicing the equipment. ONLY trained and qualified personnel who are aware of the safety hazards should perform equipment adjustments or required maintenance while the conveyor is in operation.
- Do observe all warning signs, lights, and alarms associated with the conveyor operation and maintenance, and be alert at all times to automatic operation(s) of adjacent equipment.
- Do use extreme caution near moving conveyor parts to avoid the hazard of hands, hair, and clothing being caught.
- Do not sit on, stand on, walk, ride, or cross (over or under) the conveyor at any time except where suitable catwalks, gates, or bridges are provided for personnel travel.
- Do not attempt to repair any equipment while the conveyor is running, replace any conveyor component without appropriate replacement parts, or modify the conveyor system without prior approval by the manufacturer.
- Do not operate the conveyor until all safety guards are securely in place, all tools and non-product materials are removed from or near the conveying surfaces, and all personnel are in safe positions.
- Do not remove or modify any safety devices provided on or with the conveyor.
- Do not clear jams or reach into any unit before first turning off the equipment power source(s) and affixing appropriate lockout/tagout device(s).

Parts Replacement

To minimize production downtime, selected conveyor spare parts should be stocked for replacement of defective components when required. If quantity requirements or code numbers are not indicated on the conveyor parts list, refer to the equipment bill(s)-of-materials. For added convenience, a list of selected spare parts is included in this manual (see Section I).

Factory Assistance

Contact Field Service for installation, operation, or maintenance assistance, or Customer Service and Support for replacement parts.

Installing the Case Deflector

Preparation

Before installing the Case Deflector, prepare the unit as follows:

- To prevent damage to the air filter assembly, remove the bottom cover from the air filter (see Figure G - 1).
- Disconnect the cylinder-rod clevis from the pivot arm (see Figure G - 2). Remove the retaining ring, and remove the clevis pin. To avoid damaging the retaining-ring flanges, use a punch to remove the clevis pin.
- To make the case deflector easier to handle during installation, remove the deflector arm from the pivot assembly. It is not necessary to disassemble the bull-nose weldment from the arm faces (see Figure G - 3). Remove 12 carriage bolts, and slide the deflector arm away from the mounting frame.
Note that there are flat spacers between the flanges of wheel-face arms and the mounting frame.
- Remove the stiffener plate from the support frame (see Figure G - 1).

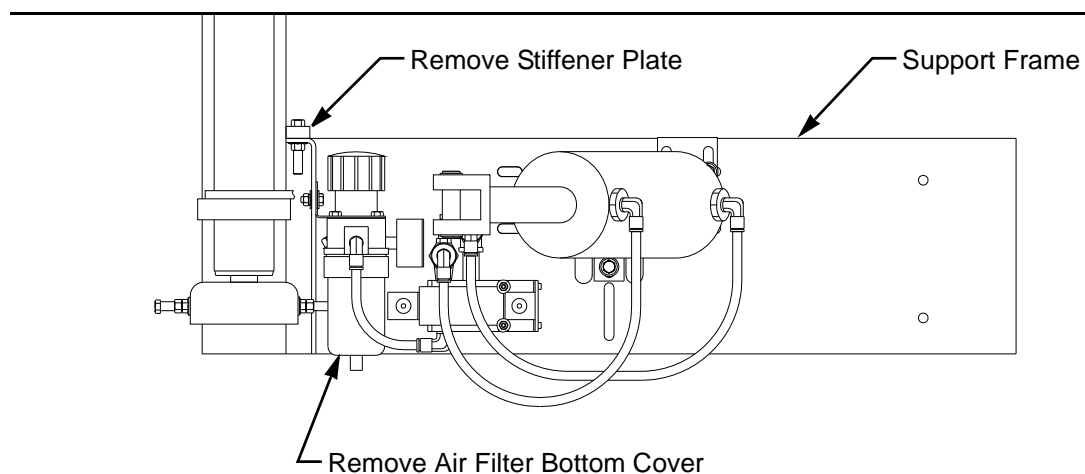

Figure G - 1 – Removing the Air Filter Bottom Cover and Stiffener Plate

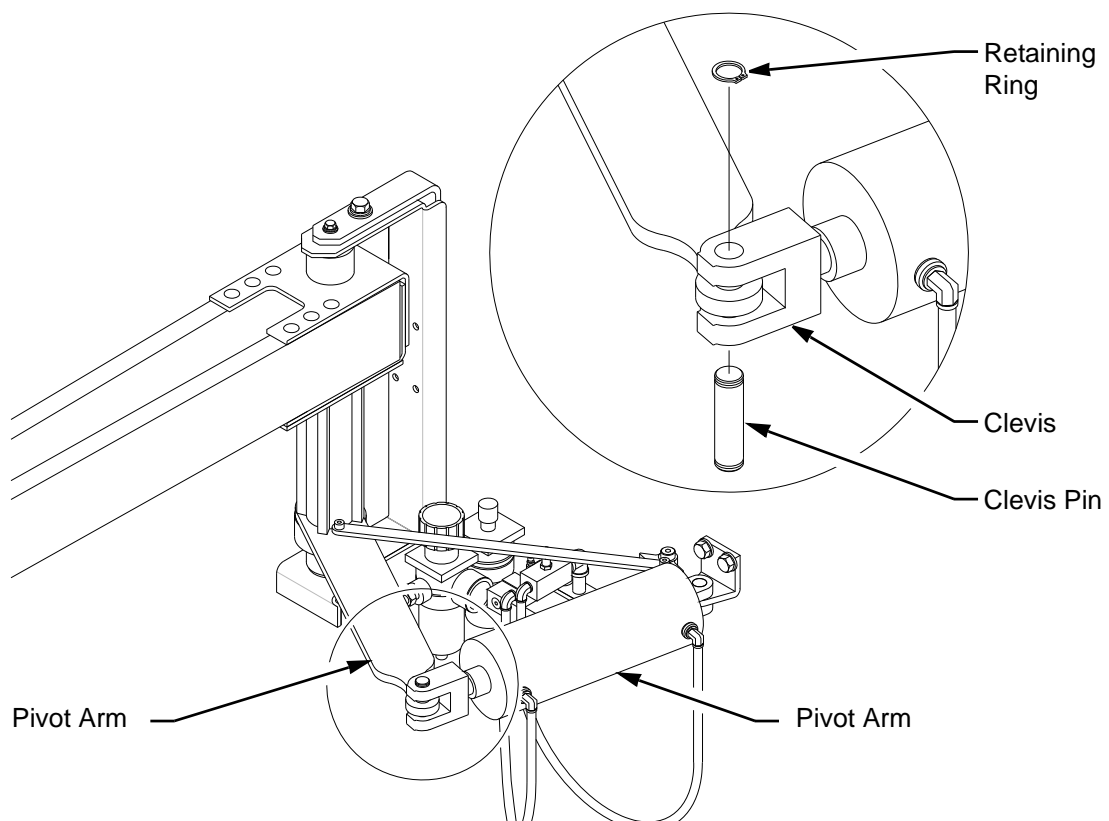

Figure G - 2 – Disconnecting the Pivot Arm

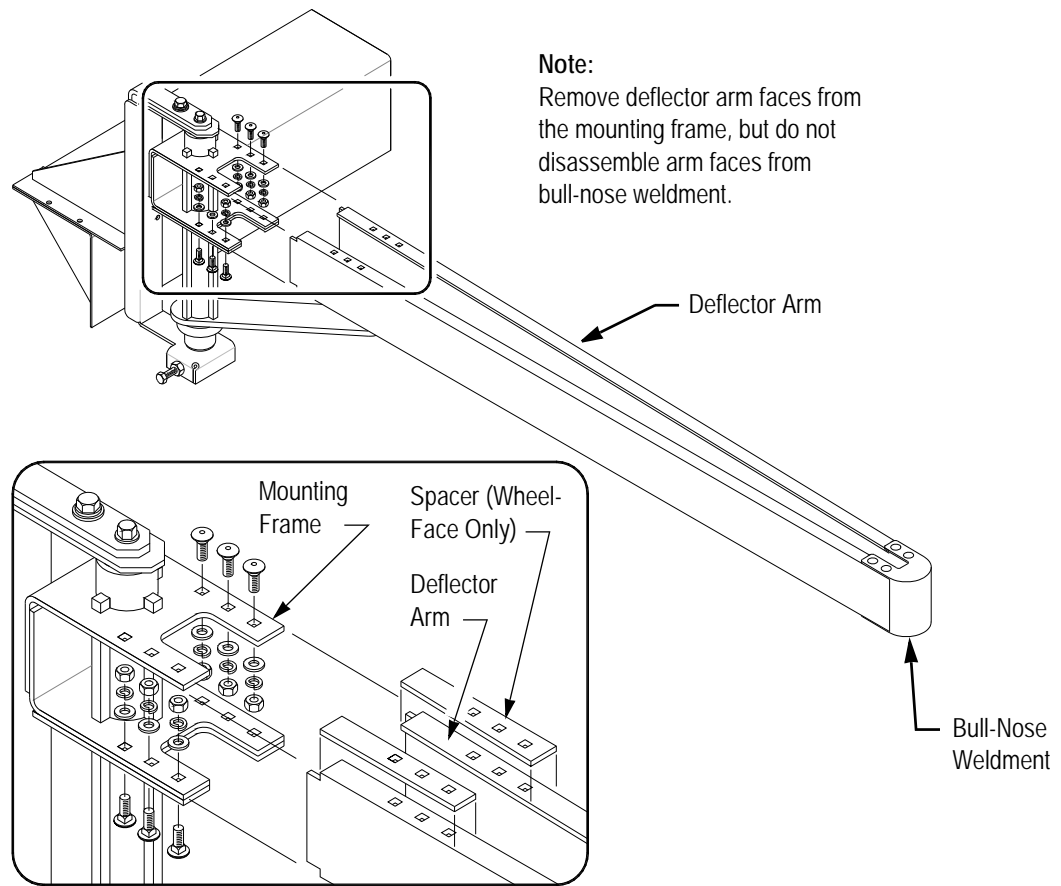

Figure G - 3 – Removing the Deflector Arm

Determine the Installation Location

The correct mounting position for the Case Deflector is a matter of judgment, depending on the precise product-path requirements, the side-guide arrangement, etc. Typically, the Case Deflector should be mounted so that the diverted product path clears the side guides (see Figure G - 4 and Figure G - 5).

The mounting position may be adjusted to accommodate critical features at the junction. For example, if the mounting position of the side guides allows for product to hang over the junction side rail, the case-deflector mounting position may be shifted in the product-flow direction of the mainline conveyor. On the other hand, if the side guides are set in from being flush with the side rails, then the Case Deflector mounting position should be shifted in the opposite direction. Since the deflector arm must be removed for mounting the unit, the mounting location should be determined in advance.

* Note that Offset may be positive or negative, depending on application requirements. Offset shown is positive.

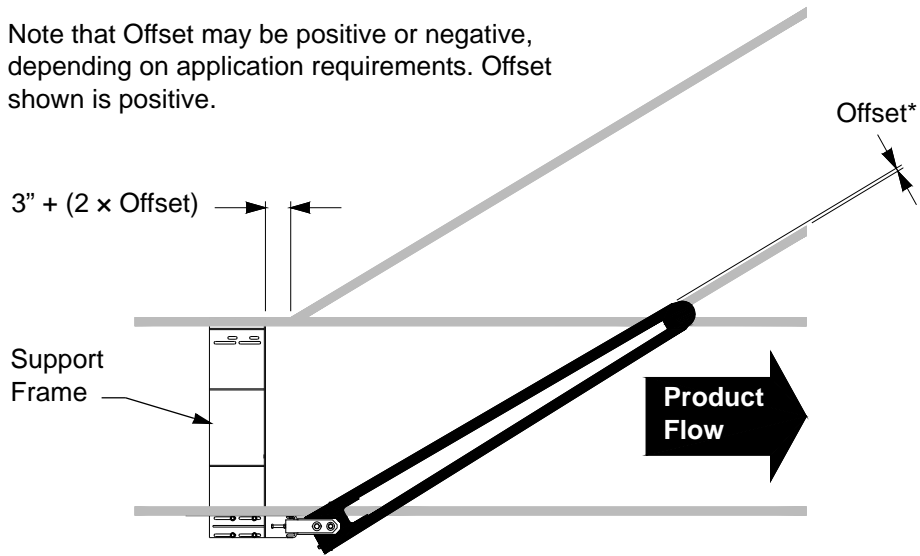

Figure G - 4 – Determining the Installation Location – Opposite Side Installation

* Note that Offset may be positive or negative, depending on application requirements. Offset shown is positive.

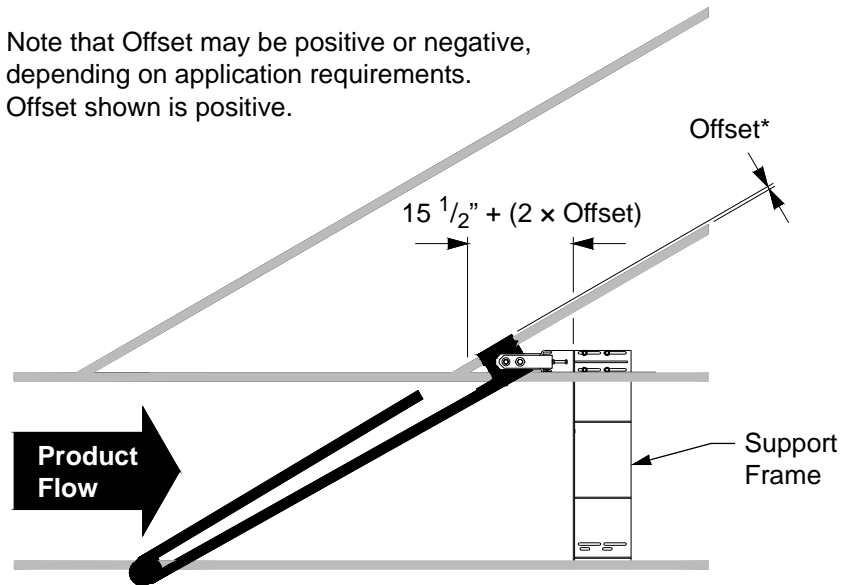

Figure G - 5 – Determining the Installation Location – Junction Side Installation

Install the Support Assembly

Place the support assembly on a platform scissor-jack with casters. Position the assembly under the mainline conveyor at the installation location. Carefully raise the assembly, with the pivot shaft oriented upright, until the top of the support frame abuts the underside of the conveyor side rails (see Figure G - 6).

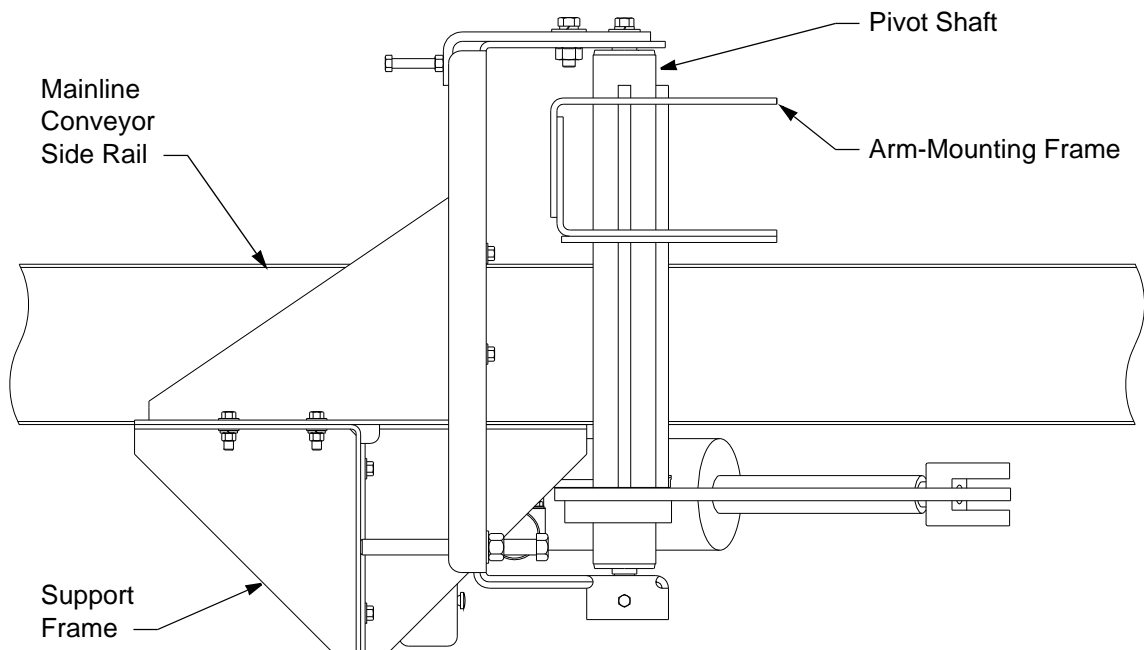

Figure G - 6 – Positioning the Support Frame

Bolt the support frame to the underside of the side rails. Be certain to install the stiffener plate on the top of the lower flange of the rail on the pivot-assembly side (see Figure G - 7). The stiffener plate is essential to providing the necessary structural support for the case deflector.

Caution!

The stiffener plate is an essential structural member. Failure to install the stiffener plate properly may result in unstable deflector operation and cause damage to the conveyor side rail.

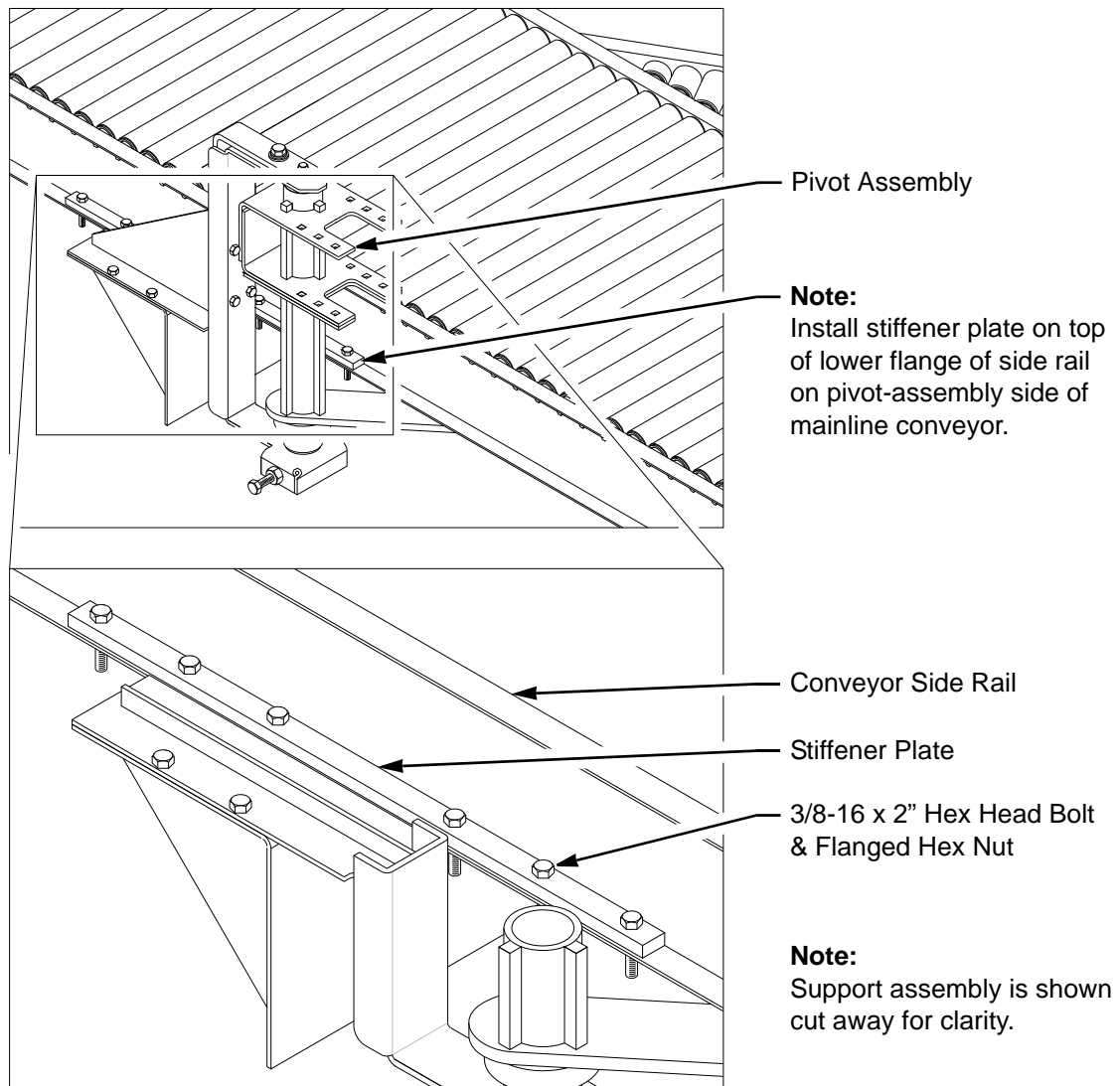

Figure G - 7 – Installing the Stiffener Plate

Install the Deflector Arm

Before installing the deflector arm, make certain that the arm faces are oriented properly.

- When plain faces are furnished on both sides, the faces are reversible.
- The faces of UHMW-face and wheel-face arms are not reversible. Make certain that in the “deflect” position, the UHMW face or wheel face is oriented toward the on-coming product.

To provide adequate support for the arm during installation, set a wood block (or similar object) on the conveying surface, and rest the free end of the deflector arm on the block. The height of the block should be equal to the proper clearance between the conveying surface and the underside of the arm. When positioning the deflector arm, note that the flanges of the arm faces fit inside the arm mounting frame. Make certain that all fasteners are tight.

Remove the support block, and swing the deflector arm manually to make sure that arm movement allows the proper clearance above the conveyor. If clearance deviates from the specified clearance by more than $\pm 1/16$ " through the full swing of the arm, adjust the pivot assembly as follows (see Figure G - 8):

- Advance-Retard Adjustment - Shifts the pivot assembly forward or backward, parallel to the direction of product travel.
- Height Adjustment - Raises and lowers the pivot assembly.
- Pitch Adjustment - Tilts the vertical axis of the pivot shaft forward or backward parallel to the direction of product travel.
- Roll Adjustment - Tilts the vertical axis of the pivot shaft from side to side, perpendicular to the direction of product travel.

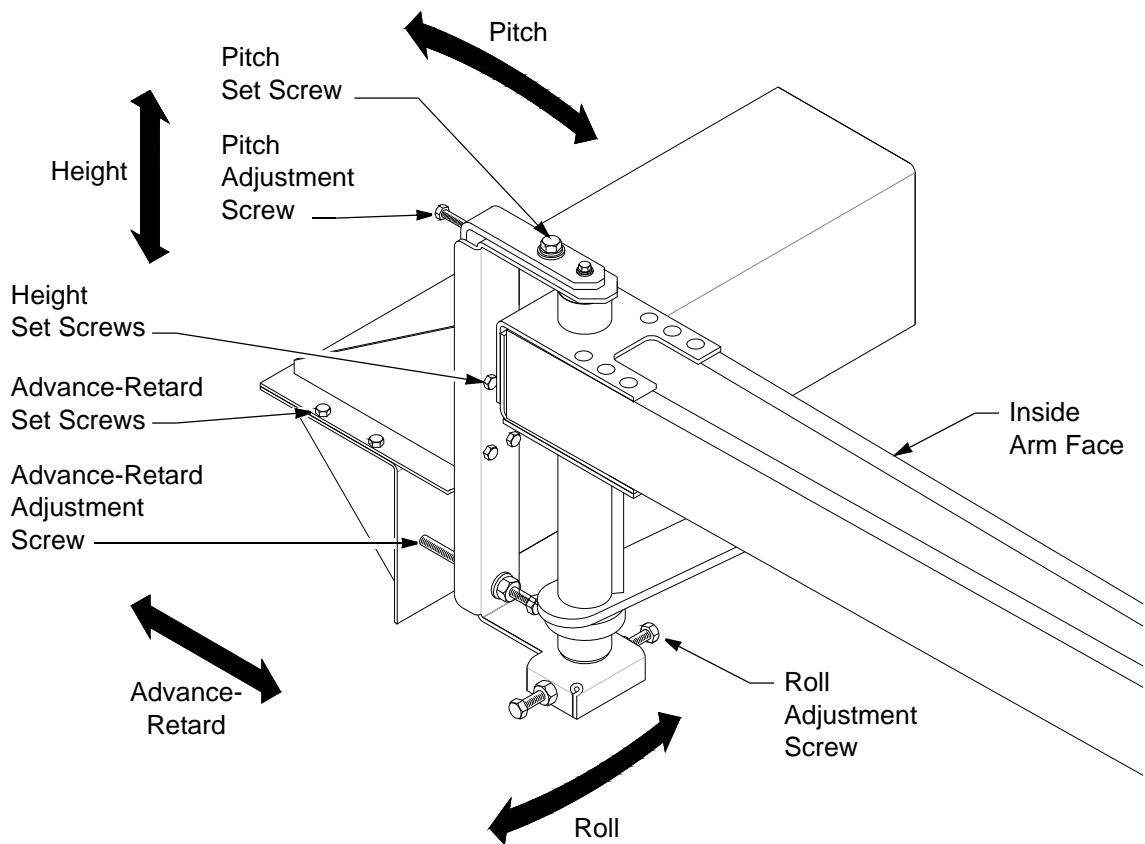

Figure G - 8 – Deflector Arm Adjustments

Make the following connections, installations and adjustments:

- Reconnect the pivot arm to the cylinder-rod clevis (see Figure G - 2).
- Replace the air filter bottom cover (see Figure G - 9).
- Connect the compressed-air supply to the air filter intake port (see Figure G - 9).
- Make electrical and control connections in accordance with the project specifications.

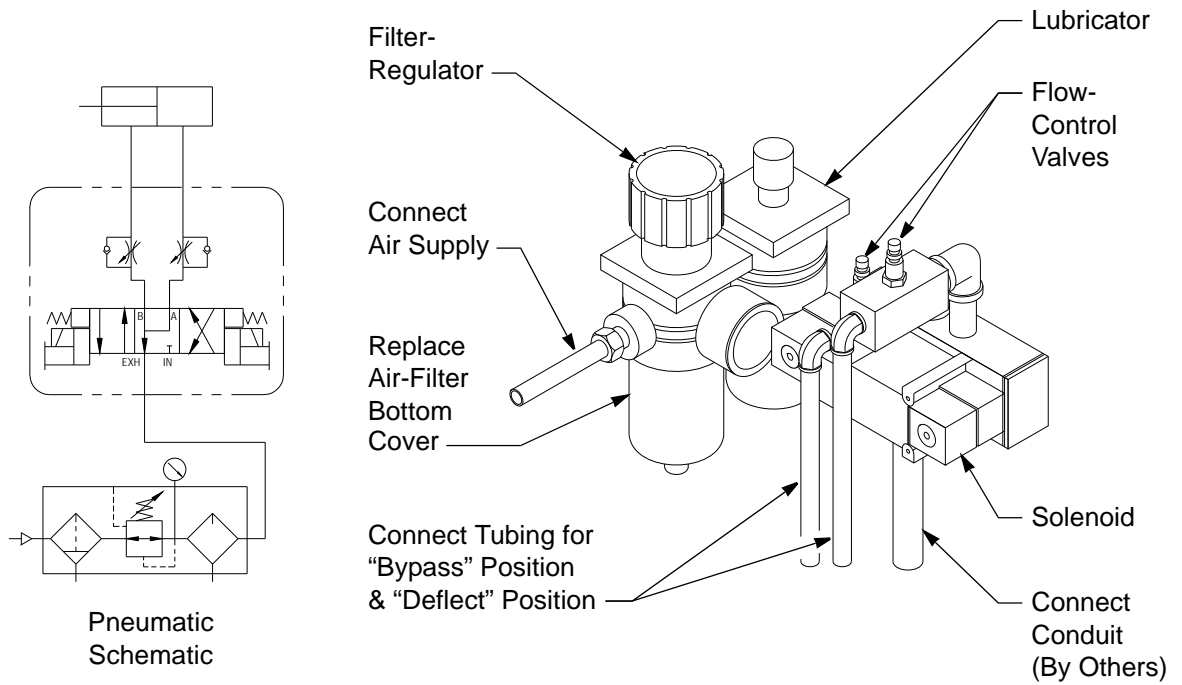

Figure G - 9 – Pneumatic Controls

Check Proximity Switches (Optional)

On units furnished with proximity switches (for detecting deflector-arm position), check the positioning of the proximity switches, and adjust as necessary (see Figure G - 10). To check the positioning, move the deflector arm to each terminal position (“deflect” and “bypass”), and check to confirm that the corresponding signal is received.

- When the deflector arm is in the “bypass” position, the “bypass” proximity switch should be “On.”
- When the deflector arm is in the “deflect” position, the “deflect” proximity switch should be “On.”

If no signal is received when a proximity switch should be “On,” adjust the position of the proximity switch closer to the rocker.

CAUTION: Make certain to provide some clearance between the proximity switch and the rocker (when the rocker is in the corresponding terminal position). If the rocker contacts the proximity switch during deflector-arm operation, damage to the proximity switch may occur.

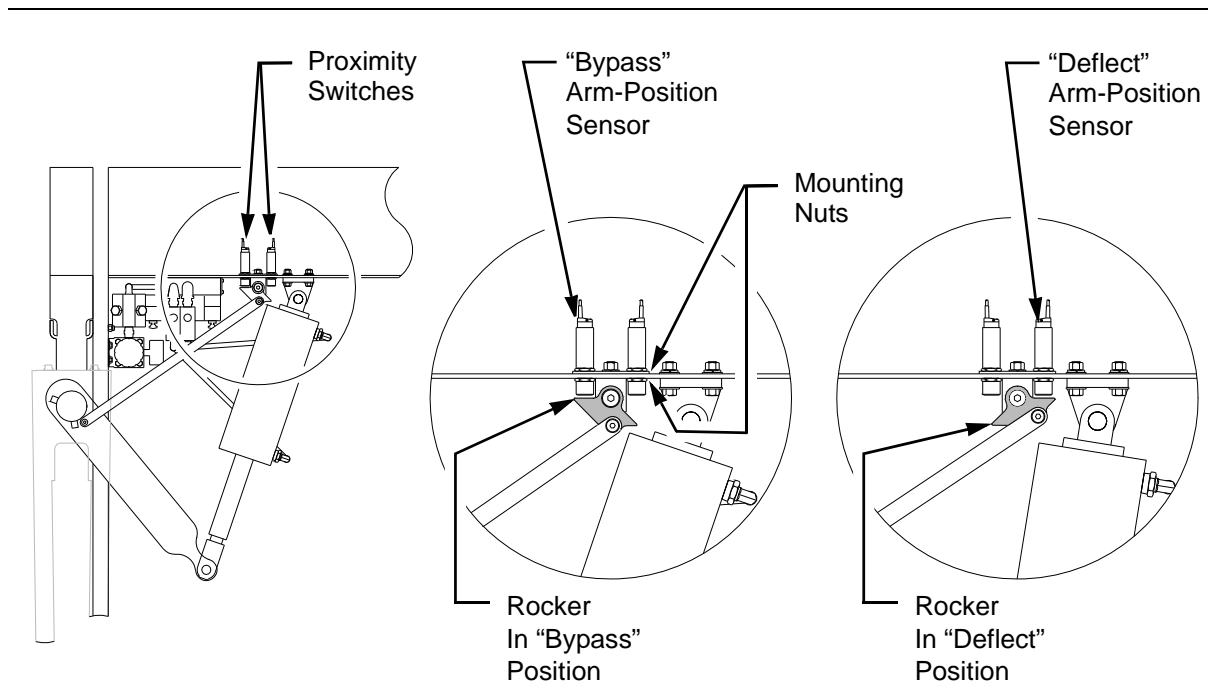

Figure G - 10 – Arm-Position Proximity Switches (Optional)

Pressure Adjustment & Final Check

- Make certain that all fasteners are tight.
- Adjust the pressure regulator (initial pressure of 60 psi is recommended).
- Adjust the two flow-control valves located on top of the solenoid and leading to the ports of the pneumatic cylinder (one for the “deflect” position, and one for the “bypass” position). Make certain that the valves are adjusted for maximum flow.
- Test-operate the case deflector by activating the solenoid manually. Observe the speed of operation and the amount of shaking of the arm and of the mainline conveyor at the end of both arm movements.
- Adjust the pressure regulator and the two flow-control valves as necessary to achieve the desired cycle speed. Make certain that the cycle speed does not shake the case-deflector assembly or mainline conveyor excessively.
- Make certain that all fasteners are tight.
- Repeat the test operation and recheck as necessary to ensure that the installation is secure.

When secure installation and proper operation are verified, place the unit in service.

SECTION H: MAINTENANCE

CAUTION: Before performing maintenance on a conveyor, make certain that the power disconnect is locked in the “Open” position and tagged to prevent accidental or unexpected application of power.

Do not perform maintenance while the conveyor is running unless specifically instructed to do so in this manual.

Maintenance must be performed only by qualified personnel who are trained in normal and emergency operations of the conveyor and who are knowledgeable of all safety devices, their locations, and their functions.

Before restarting a conveyor:

- Remove all foreign objects from the conveyor.
- Be sure that all guards and safety devices are properly installed and working.
- Make sure that all persons are clear of the conveyor and are aware that the conveyor is about to be restarted.

Initial Start-Up & Run-In Period

Before starting up the conveyor initially, perform the following checks, and take corrective action as necessary:

- Check the general structure and all safety guards and devices to ensure that the unit has been installed properly, and make certain that all fasteners are tightened securely.
- Make certain that the fasteners securing the deflector arm faces to the mounting frame are tight.
- Check that the set screws in the pivot assembly are properly adjusted and tight.
- Check the settings of the pressure regulator and of the flow-control valves.

During the start-up and run-in period, spend ample time watching the conveyor system, and especially listening to it. Become familiar with the sounds of ordinary operation. Most problems that occur make distinctive sounds – thumps, rattles, and squeaks – but these distinctive sounds can be recognized only in contrast to the sound of normal operation as a baseline. The importance of listening to the sound of normal operation cannot be underestimated.

For the first week of operation, check the listed items daily and take corrective action as necessary. For the following three weeks, check the items listed weekly. After the first four weeks, follow the recommended schedule.

Scheduled Maintenance

During the first 40 hours of operation, all newly installed equipment should be inspected frequently and serviced as needed. Thereafter, an appropriate maintenance program should be established and followed.

A recommended schedule for preventive maintenance is presented herein (see Table H - 1). The recommended schedule is predicated on typical operation for 8 hours per day, 40 hours per week, above freezing temperature (40°F to 110°F). Continuous-duty operation or operation under extreme environmental conditions may require more frequent maintenance. Operators and maintenance personnel should continually monitor the equipment under actual operating conditions and make adjustments to the recommended schedule accordingly.

Maintaining separate service log sheets on each type of conveyor is recommended for plants operating more than one shift. Each log sheet should show the dates, detailed inspection and service information, and the names or initials of persons performing the inspection or service.

Table H - 1 – Scheduled Maintenance Summary

Interval	Maintenance	Lubrication	Oil Level	Tension	Wear	Alignment	Fasteners	Set Screws	Proper	Physical	Operation
Daily (8 Hours)	General Inspection						X	X	X	X	X
	Structure				X		X			X	
	Electrical Devices										X
Weekly (40 Hours)	Control Devices						X			X	X
	Safety Guards and Devices						X			X	
Monthly (175 Hours)	Air Pressure										
	Arm Movement										X
	Arm Clearance					X					
	Pivot Assembly				X	X		X	X	X	X
Quarterly (525 Hours)	Air Filter									X	
	Air Lubricator		X							X	
	Support Assembly						X			X	

Daily Maintenance

Every 8 hours of operation

At the beginning of every shift, conduct a general walk-through inspection of the entire conveyor system while it is running. Walk slowly and listen attentively for unusual noises. Keep a sharp eye for unusual movement of any conveyor component. If any irregularity is detected, inspect the conveyor closely to identify the cause.

- If product has spilled or fallen out of its packaging and become lodged in the conveyor, stop the conveyor and remove the product. Liquids collecting on a conveyor can cause slippage.
- If a conveyor component has been damaged, determine whether the damage presents an unsafe condition. If an unsafe condition does exist, interrupt conveyor operation immediately, and correct the problem before resuming operation. If an unsafe condition does not exist, make a note of the damage, and schedule repairs in accordance with company maintenance policy. It may be useful to mark the location of the problem in order to find it again at the time for repair.
- If any problem is the result of failure to follow established procedures, make certain that the persons responsible understand and follow the proper procedures. If the established procedures have been followed, discuss the problem with the appropriate supervisor to determine whether procedures should be revised.

Examine the structure to detect damaged or wearing components, and to ensure that the structure is sound and that fasteners are tight. Check the physical condition of the conveyor for loose fasteners, damaged or wearing components, buildup of dust and product spillage. Note that carton dust entering bearings can cause them to deteriorate and shorten the service life of rollers.

Inspect electrical devices, such as proximity sensors, etc. Make certain that they are positioned and aligned properly. Clean lenses and reflectors of optical devices daily. For additional maintenance measures, refer to the technical literature provided by the manufacturer of the device.

Weekly Maintenance

Every 40 hours of operation

Check all control devices for physical condition and proper operation, and make certain that all fasteners are tight.

Make certain that all guards and safety devices are intact and that all fasteners are tight. Check for signs of oil leakage on the floor. If leakage persists or the amount of leakage is significant, repair or replace the leaking device.

Monthly Maintenance

Every 160 hours of operation

Check the deflector arm for proper operation. Check the clearance between the deflector arm and the conveying surface. Check the pivot assembly for physical condition and for proper adjustment. Make certain that the pivot assembly set screws are tight. Check the air pressure.

Quarterly Maintenance

Every 520 hours of operation

Filter-Regulator – Check the physical condition of the air filter. If the filter element is laden with sediment, clean the filter as follows:

- Depressurize the system.
- Unscrew the polycarbonate bowl.
- Unscrew the filter element from the filter head.
- Wash the filter element with a cleaning solvent.
- Dry the filter element thoroughly.
- Reinstall the filter element to the filter head.
- Replace the polycarbonate bowl.
- Repressurize the system.

CAUTION: To avoid closing internal ports, be careful not to screw fittings too far into the body of the filter unit. Normally finger-tight plus one turn will seal.

Lubricator – Check the oil level in the air lubricator and replenish as necessary. Oil may be added to the lubricator while the system is under pressure. Replenish oil as follows:

- Remove the filler plug (located on top of the lubricator body) slowly to relieve pressure in the bowl.
- Insert a long spout or funnel into the filler hole.
- Add oil.
- Remove the spout or funnel.
- Replace the filler plug.

Troubleshooting

The troubleshooting information provided herein pertains specifically to the case deflector. For additional troubleshooting information, refer to the “Maintenance” section of the manual for the conveyor on which this equipment is installed.

CAUTION: Do not clear jams or reach into any unit unless the electrical power for the mainline and junction conveyors is turned “Off.” Make certain that all moving parts have stopped moving completely. To avoid personal injury and equipment damage, lock out and tag out the conveyor controls before attempting to correct any malfunction.

Table H - 2 – Basic Troubleshooting

Problem	Cause	Solution
Carton collides with moving deflector arm	Arm movement is too slow.	Determine whether arm movement is too slow in one direction or in both directions. <ul style="list-style-type: none"> • If arm movement is too slow in one direction, adjust the corresponding flow-control valve to increase flow rate. • If arm movement is too slow in two directions, adjust the pressure regulator to increase pressure.
	Product spacing is too tight.	Take corrective action to increase product spacing.
Arm movement is too slow in one direction	Flow-control valve setting is too low.	Adjust flow-control valve to increase flow rate.
Arm movement is too slow in both directions	Pressure regulator setting is too low.	Adjust pressure regulator to increase pressure.
	Both flow-control valve settings are too low.	Adjust both flow-control valves to increase flow rate.
Arm movement is too fast in one direction	Flow-control valve setting is too high.	Adjust flow-control valve to decrease flow rate.
Arm movement is too fast in both directions	Pressure regulator setting is too high.	Adjust pressure regulator to decrease pressure.
	Both flow-control valve settings are too high.	Adjust both flow-control valves to decrease flow rate.

Problem	Cause	Solution
Carton or product damage results from contact with deflector arm	Arm movement is too fast.	Determine whether arm movement is too fast in one direction or in both directions, and adjust the flow-control valves accordingly.
	Deflector arm is still moving when product arrives.	Adjust timing of arm action in relation to product movement. Adjust product spacing as necessary.
	Arm touches carrying surface.	Adjust arm clearance to within design limits. Reconfigure product as necessary to avoid damage with existing clearance.
	Friction between product and conveying surface is too large.	Reconfigure product, or mainline conveyor, or both, as necessary to reduce coefficient of friction.

SECTION I: SPARE PARTS

Parts Replacement

Certain parts are classified as "spare parts" because they are necessary for the component to function and prone to failure. The manufacturer recommends stocking a supply of these spare parts in order to minimize down time when failure occurs. The illustrations that follow show these parts, their locations, and related parts which may not be classified as spare parts. Callouts in the illustrations are keyed to tables which follow the illustrations. The tables list part numbers and descriptions and indicate whether each part is classified as a spare part. Instructions for installing parts is provided in Section G, *Installation Procedures*.

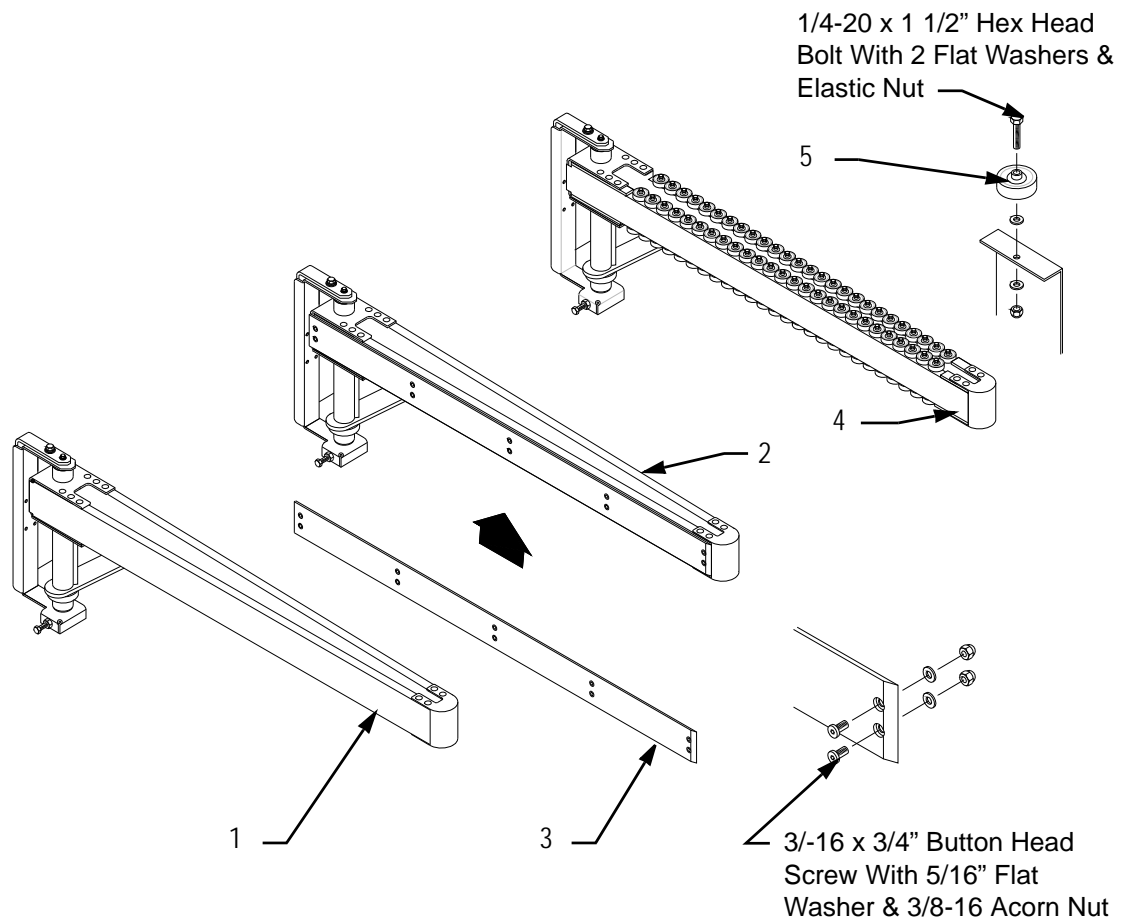

Figure I - 1 – Case Deflector Arm Parts

Table I - 2 –Case Deflector Arm Face Component Part Numbers (see Figure I - 1)

Key	Part Description	Mainline Conveyor Width (Inches)				
		16	22	28	34	40
1	Arm Rail, Plain Face	737843	737844	737845	737846	737847
2	Arm Rail, UHMW Face	737848	737849	737850	737851	737852
3	UHMW Plate	737853	737854	737855	737856	737857
4	Arm Rail, Wheel Face	737858	737859	737860	737861	737862
5	Skate Wheel, 1 15/16" O. D., 1/4" I. D.	1000422	1000422	1000422	1000422	1000422

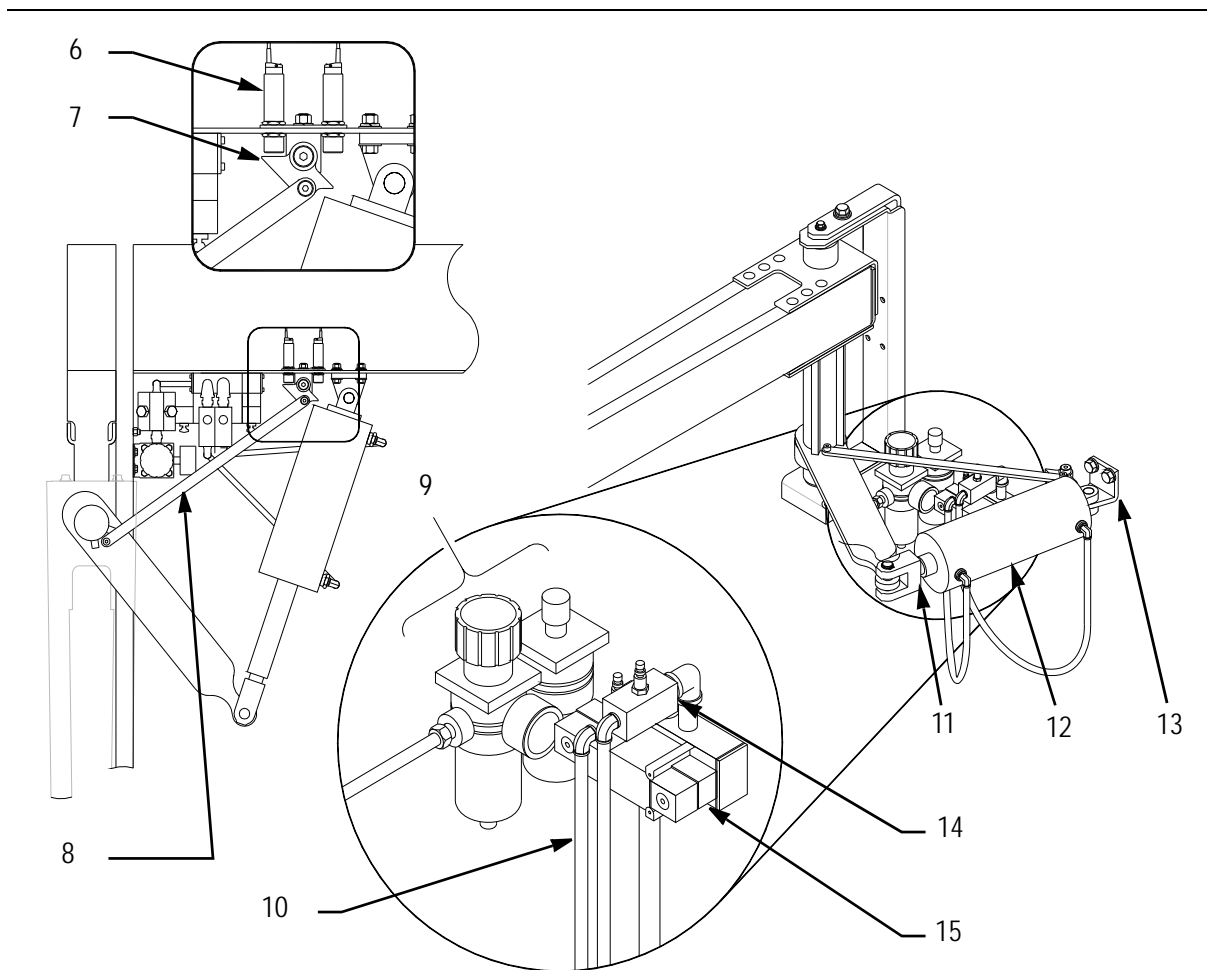

Figure I - 3 – Control Components

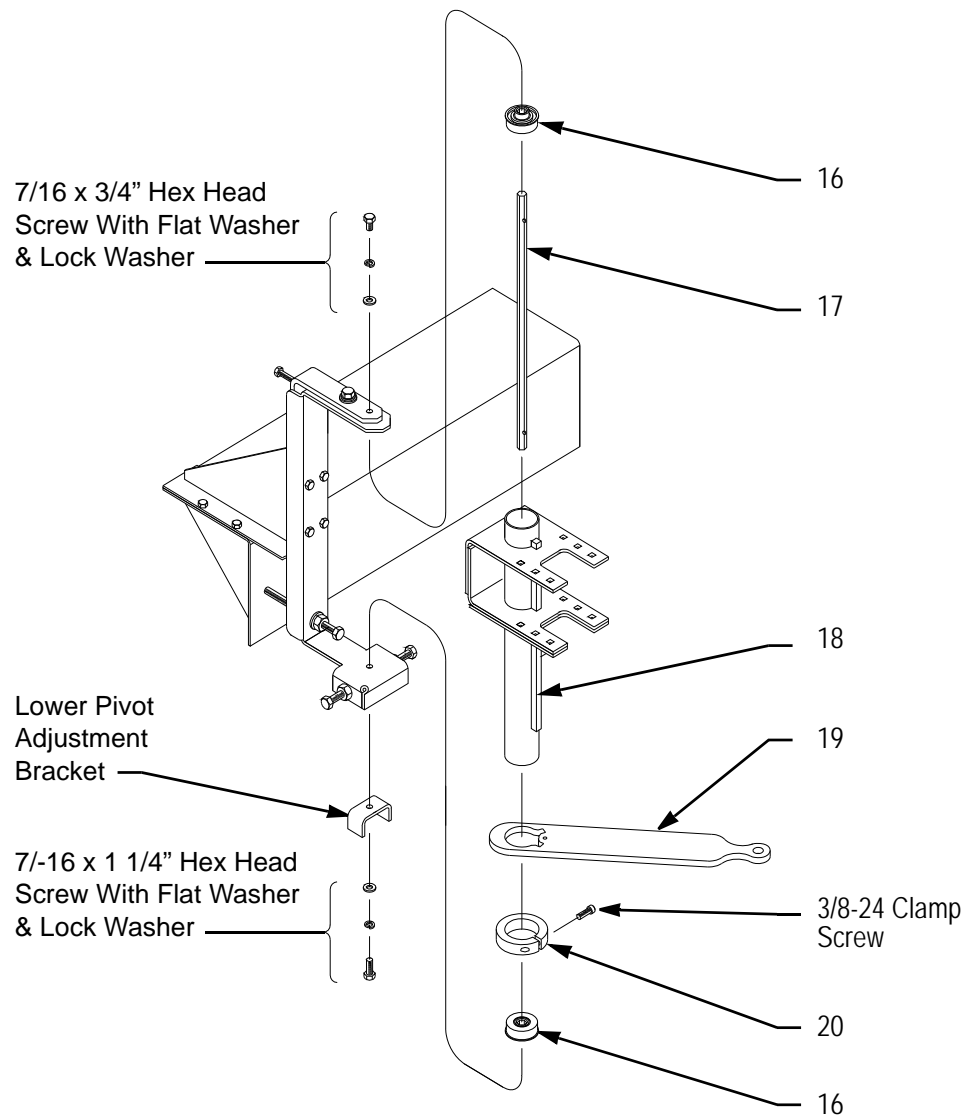

Figure I - 4 – Pivot Assembly Components

Table I - 5 – Control & Pivot Assembly Components

Key	Part Description	Part Number	Spare Part
6	Sensor, Proximity 18mm DC	270271	Yes
7	Case Deflector Rocker (Proximity Switch Target)	737886	Yes
8	Case Deflector Rocker Arm	737885	Yes
9	Filter, Regulator, Lubricator & Gage Assembly	271736	Yes
10	3/8" Nylon Tube, Alkon # NY66-N (Specify length in feet)	271570	Yes
11	Bimba Cylinder Clevis & Pin, ARC2	737903	Yes
12	Bimba Cylinder, DWC-1258-2	737901	Yes
13	Bimba Cylinder Mounting Kit, MC-125	737902	Yes
14	Flow Control Valve	270975	Yes
15	Solenoid Valve, Case Deflector		Yes
	Mac 24 Volt	270978	
	Mac 120 Volt	742265	
16	Bearing, Miller MF-2511-HSP	350372	Yes
17	Case Deflector Pivot Roller Axle, P	737906	Yes
18	Case Deflector Pivot Roller Assembly (Includes Items #16 and #17)	737898	No
19	Case Deflector Pivot Bracket, Cylinder Rod End	737888	Yes
20	Shaft Collar, CTC-174, Reid Tool	737904	No